

GENERAL DATA

Application:	LBP
Refrigerant:	R404A
Expansion Device:	C-V
Weight:	17.1 kg
Receiver:	0.5 liter
Voltage/Frequency:	220 - 240 V 50 ~
Height:	17.1 mm
Length:	430 mm
Width:	290 mm
Institute Approvals:	CE

EXTERNAL DIMENSIONS

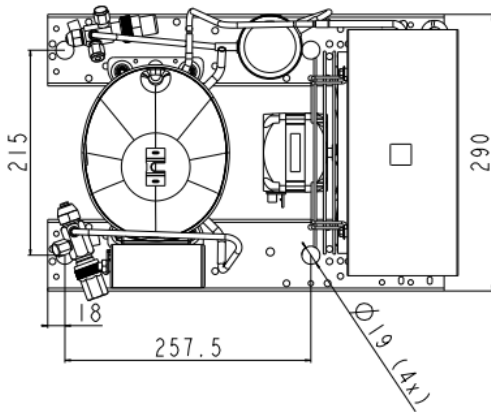
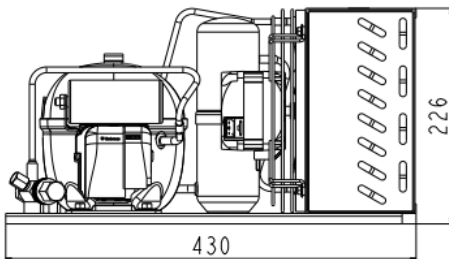

WIRING DIAGRAM

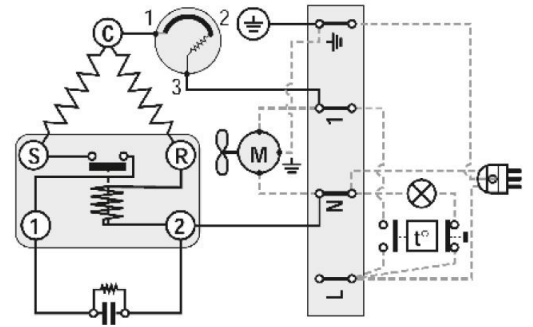

OPERATING ENVELOPE

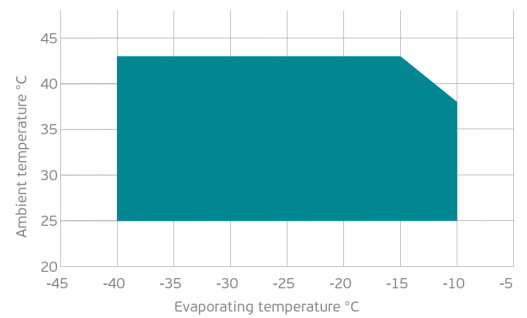

COMPONENTS (SPARE PARTS)

fankit:	10W 200/28/5B	1996700
valve_disch:	FLARE 1/4"	2110025
compressor:	EMT2117GK	912BA67...AR

valve_suca:	FLARE 3/8"	2110024
condenser:	3R8T	2451204
elkit:	ELCOM EMT2117GK	912BA67K3A

For additional accessories please contact our technical support

ELECTRICAL DATA

Motor Type:	CSIR -
Locked Rotor Amperage (LRA):	7.7 A
Max.Current:	1.4 A

At maximum evaporating temperature and maximum ambient temperature.

FAN MOTOR

Number:	1 -
Shaft Power:	10 W
Air Flow:	300 m ³ /h
Blade Diameter:	200 mm

PERFORMANCE CURVE DATA

Standard: EN13215-RG20 / return gas 20°C, subcooling 3K

50 Hz

	Evaporating Temperature (°C)	Cooling Capacity (W)	Power Consumption (W)	Current Consumption (A)	Efficiency (W/W)
25 °C Ambient Temperature	-10°C	439	254	1.56	1.73
	-15°C	371	232	1.47	1.60
	-20°C	309	212	1.40	1.46
	-25°C	254	193	1.34	1.32
	-30°C	205	176	1.28	1.17
	Rated point -35°C	160	160	1.23	1.00
	-40°C	121	146	1.18	0.83
32 °C Ambient Temperature	-10°C	399	262	1.61	1.52
	-15°C	337	239	1.52	1.41
	-20°C	281	218	1.44	1.29
	-25°C	231	199	1.37	1.16
	-30°C	186	181	1.32	1.03
	Rated point -35°C	146	165	1.27	0.89
	-40°C	111	151	1.22	0.74
43 °C Ambient Temperature	-15°C	289	254	1.62	1.14
	-20°C	239	231	1.53	1.04
	-25°C	196	211	1.46	0.93
	-30°C	158	192	1.40	0.82
	Rated point -35°C	124	175	1.35	0.71
	-40°C	94	160	1.30	0.59