

PART NO	MODEL NO	A	B
497-3535-00	ZB56/75	3.30 [0.14]	537.84 [21.17]
497-3535-01	ZB92	3.20 [0.13]	545.43 [21.47]

SPECIFICATIONS	
ES NO.	DESCRIPTION
ES22-122	PACKAGING
ES81-159	CLEANLINESS
ES81-250	IDENTIFICATION
ES92-155	CONVERSION-METRIC
ES92-167	REGULATORY COMPLIANCE

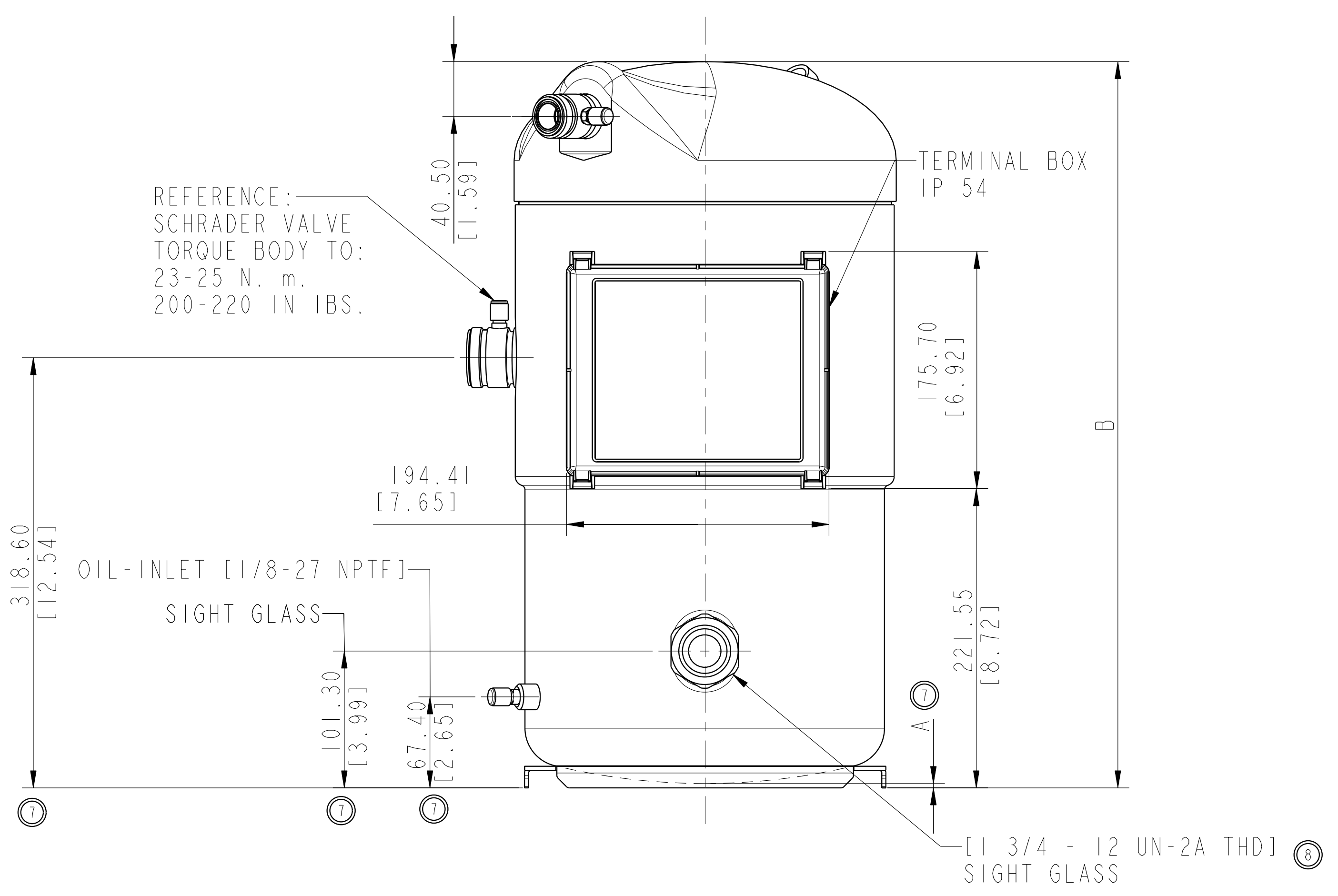

DUE TO ACCUMULATED ASSEMBLY TOLERANCES THE LISTED COMPONENTS MAY VARY FROM THE MOUNTING HOLES AS TABULATED

SUCTION FITTING	±3.0 [0.12]
DISCHARGE FITTING	±3.0 [0.12]
LIQUID INJECTION	±3.0 [0.12]



INTERPRET PER ASME Y14.5M-1994 AND EMERSON CLIMATE TECHNOLOGIES, INC. DESIGN STANDARDS DS2002 DO NOT SCALE DRAWING

THIRD ANGLE PROJECTION

CRITICAL PRODUCT CHARACTERISTIC

UNLESS OTHERWISE SPECIFIED DIMENSIONS ARE MILLIMETER OR (INCH) TOLERANCES:

1-PLACE ± 0.4
2-PLACE ± 0.15
ANGULAR ± 0.5°

ENG NOTICE NO.	REV. NO.	REVISIONS	DATE	BY	CHKD	APPR
ECN005286	8	CHANGED SIGHT GLASS & REVIEWED DIM	03-22-12	JS	MD	VC
32-0308-008	7	REFERENCE, TABLE UPDATED & CHANGE FORMAT + ADD ES	03-05-08	JB	NM	VC
32-1103-025	6	REDRAWN AND REVISED	05-18-04	G1K	SBM	CHK
32-0998-060	0	RELEASED	09-29-98	PMM	SBM	CHK

CONFIDENTIALITY NOTICE

THIS DRAWING AND INFORMATION CONTAINED HEREIN ARE THE EXCLUSIVE PROPERTY OF EMERSON CLIMATE TECHNOLOGIES, INC. AND SHALL BE RETURNED UPON DEMAND AND SHALL NOT BE REPRODUCED IN WHOLE OR IN PART, DISCLOSED TO ANYONE ELSE OR USED, WITHOUT THE WRITTEN CONSENT OF EMERSON CLIMATE TECHNOLOGIES, INC.

MATERIAL SPECIFICATION	DRAWN BY	SUPERSEDES DWG. NO. / REV. NO.
N/A	OTL	497-3535-00 / 5

TITLE	DRAWING NUMBER	SHEET 1 OF 1	DWG
REF DWG-WELD COMP ASSM	497-3535-00	4	SIZE

UNCONTROLLED - DO NOT MODIFY

©COPYRIGHT EMERSON CLIMATE TECHNOLOGIES, INC. - CONFIDENTIAL