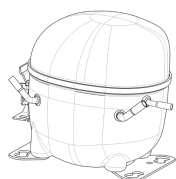

220-240V 50 1~**GENERAL DATA**

Application: LBP
Refrigerant: R404A
Evaporating Temperature Range: -40°C to -10°C
Compressor Cooling: Fan
Fan air flow: 520 m³/h
Type: Hermetic reciprocating
Technology Type: On-Off
Expansion Device: Capillary Tube or Expansion Valve
Packing Quantity: Multi - 28 pcs
Displacement: 16.8 cm³
Horse power: 1 hp

Approvals:     

**MECHANICAL DATA**

Bore: 31.19 mm
Stroke: 22 mm
Oil Charge: 350ml +/-15ml
Free Internal Volume: 2.1 cm³
Maximum Recommended Refrigerant Charge: 350 g
Oil Type Configuration: Polyolester
Oil Type Viscosity: ISO22
Compressor pressurization: Dry air charge
Weight: 12.3 kg

ELECTRICAL DATA

Motor Type: CSR
Starting Torque: HST
Voltage working range at 50 Hz: 198-254 V
Maximum Motor Temperature: 130 °C
Start Winding Resistance: 11.03 Ω (± 10%) at 25°C
Run Winding Resistance: 5.15 Ω (± 10%) at 25°C
Locked Rotor Amperage (LRA): 21 A

MOUNTING ACCESSORIES

	Description	Code
Terminal Board:	no	-
Anchorage:	no	-
Capacitor Bracket:	no	-
Washer:	no	-
Pin:	no	-
Clip:	no	-
Rotolock valve:	no	-
Grommets:	yes	2221011
Sleeves:	yes	2222018
Overload Protector Bracket:	yes	2075299
Cover:	yes	2075278

ELECTRICAL COMPONENTS

	Component type	Description	Code
Start Capacitor:		88-108 MFD 330V	2252269
Run Capacitor:		15 MFD	2253310
Starting Device:	Potential relay	RVA6M3C-114	1253014
Motor Protection:	External 3/4"	MSP18LJ-3261	2321146
CSR / CSIR Box:	yes		1272381

EXTERNAL CHARACTERISTICS

Base Plate: European
Tray Holder: No
Height: 206 mm

	Internal Diameter (mm)	Material	Shape
Suction Connector	8.1	Copper	Slanted 42°
Discharge Connector	6.1	Copper	Straight

RATED POINT DATA

Cooling Capacity (W)	Power Consumption (W)	Current Consumption (A)	Gas Flow Rate (kg/h)	Efficiency (W/W)
±5%	±5%	±5%	±5%	±7%
908	645	3.00	21.00	1.41

Test condition: ASHRAE, Fan, Return Gas 32.2°C, Evaporating: -23.3°C, Condensing: 54°C, Ambient: 32.2°C, Liquid: 32.2°C

PERFORMANCE CURVE DATA

220V 50Hz

Condensing Temperature (°C)	Evaporating Temperature (°C)	Cooling Capacity (W)	Power Consumption (W)	Current Consumption (A)	Gas Flow Rate (kg/h)	Efficiency (W/W)
		±5%	±5%	±5%	±5%	±7%
35°C	-10	1 741	770	3.60	41.10	2.26
	-15	1 437	693	3.24	33.69	2.07
	-20	1 167	621	2.90	27.20	1.88
	-25	932	553	2.59	21.61	1.68
	-30	731	491	2.31	16.88	1.49
	-35	564	434	2.05	12.98	1.30
	-40	432	382	1.81	9.90	1.13

Condensing Temperature (°C)	Evaporating Temperature (°C)	Cooling Capacity (W)	Power Consumption (W)	Current Consumption (A)	Gas Flow Rate (kg/h)	Efficiency (W/W)
		±5%	±5%	±5%	±5%	±7%
45°C	-10	1 672	846	3.92	39.39	1.98
	-15	1 377	753	3.49	32.22	1.83
	-20	1 115	666	3.10	25.93	1.67
	-25	886	587	2.74	20.50	1.51
	-30	690	514	2.42	15.89	1.34
	-35	526	449	2.12	12.08	1.17

Condensing Temperature (°C)	Evaporating Temperature (°C)	Cooling Capacity (W)	Power Consumption (W)	Current Consumption (A)	Gas Flow Rate (kg/h)	Efficiency (W/W)
		±5%	±5%	±5%	±5%	±7%
55°C	-10	1 582	923	4.27	37.20	1.71
	-15	1 300	812	3.76	30.36	1.60
	-20	1 050	710	3.30	24.36	1.48
	-25	831	617	2.88	19.18	1.35
	-30	643	533	2.51	14.78	1.20

Test condition: ASHRAE, Fan, Return Gas 32.2°C, Ambient: 32.2°C, Liquid: 32.2°C

ASSEMBLY INSTRUCTION

WIRING DIAGRAM

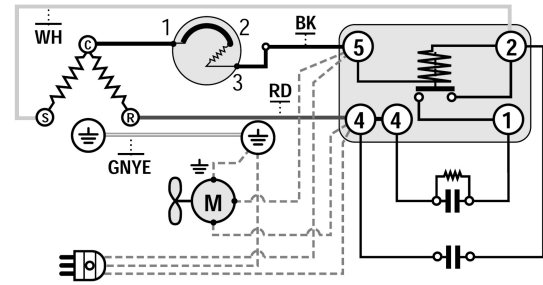
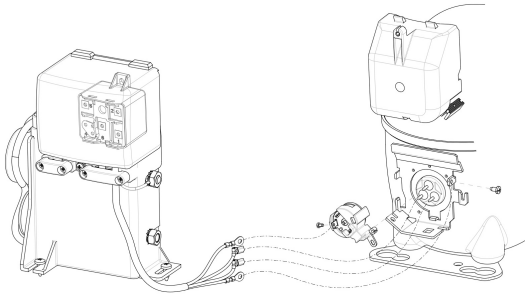

OPERATING ENVELOPE

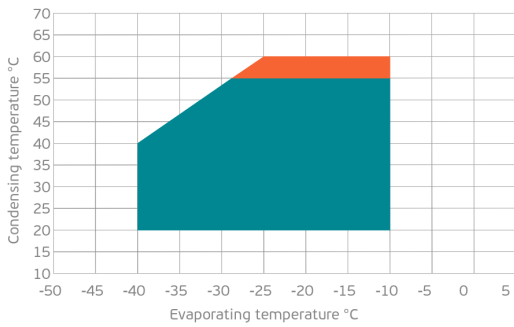

- Operating Condition
- Transient Condition
- Superheating

NOTE: usage of compressors outside of intended working range cannot make use of the warranty, or should be consulted with Technical support.

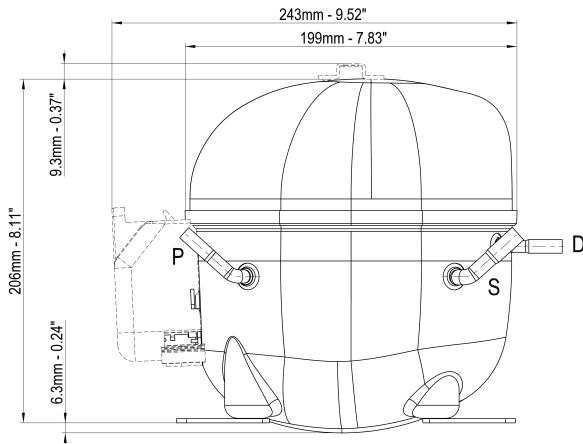

	∅ mm	∅ in	Material
S - Suction	8.10 - 8.20	0.32	Cu
P - Process	6.10 - 6.20	0.24	Cu
D - Discharge	6.10 - 6.20	0.24	Cu

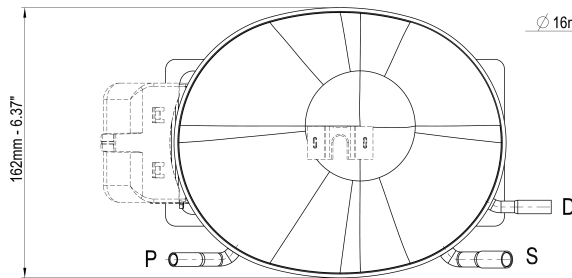

∅ 16mm - 0.63" (x6)

